

WATER METER BUSHING SPECIFICATIONS

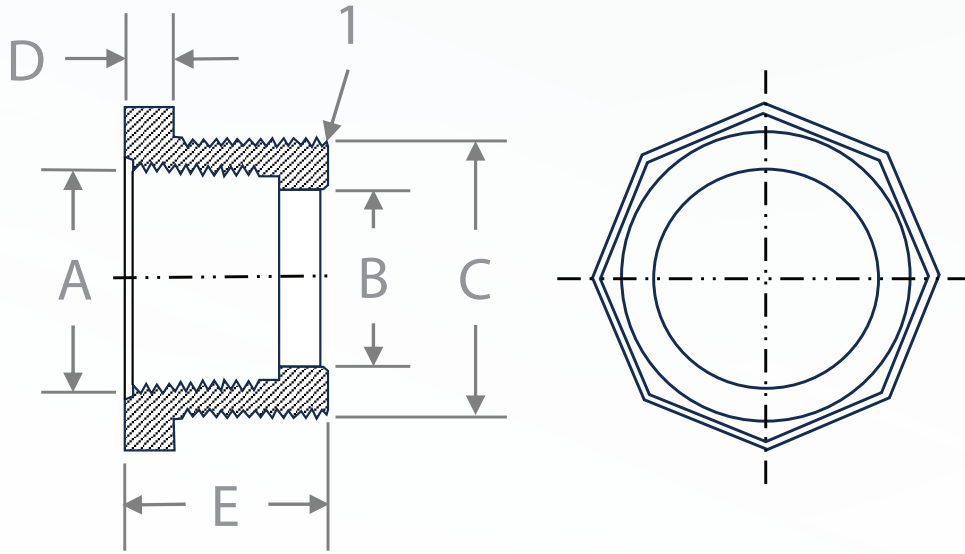

FEATURES:

- Adapt MIP to Male Meter Thread
- Casting with Lead-Free Marking
- Machined Body and Threads

PART #	PART DESCRIPTION	A	B	C	D	E
AMB075075LB	3/4" Female NPT x 3/4" Male Meter Lead Free Brass Bushing	3/4" FNPT	3/4"	1" NPSM	1/4"	1-3/16"
AMB075100LB	3/4" Female NPT x 1" Male Meter Lead Free Brass Bushing	3/4" FNPT	1-5/32"	1-1/4" NPSM	3/8"	1-5/32"
AMB100100LB	1" Female NPT x 1" Male Meter Lead Free Brass Bushing	1" FNPT	1-5/32"	1-1/4" NPSM	5/16"	1-1/8"

COMPONENT	DESCRIPTION	QTY	MATERIAL
1	Body	1	Lead Free Brass

Alexander's brass meter extensions are monitored at every step of the engineering and manufacturing process to assure the highest quality. Each extension is made of NSF-61/G certified brass.

Information provided on this sheet is considered to be correct at the time of publication.